

RCF2084 Model

Specifications & Capacities		
Machine Weight		
	Single Tailwheel	1,047 lbs. with Front Rubber Guard and Rear Metal Band.
	Dual Tailwheel	1,155 lbs. with Front Rubber Guard and Rear Metal Band.
Hitch		Category I & II with floating top linkage, Quick Hitch ready
Cutting Width		84"
Overall Width		89"
Overall Length		
	Singe Tailwheel	133 1/4"
	Dual Tailwheel	126"
Deck Height (Bottom of Deck to Bottom of Skid Shoe)		11 15/16"
Cutting Height		1 1/2" to 12"
Cutting Capacity		2" Diameter
Recommended tractor hp		45-90 hp
Power take-off speed		540 rpm
Gearbox Ratio		1:1.44
Gearbox Construction		Speed-up beveled gears, cast iron housing, 1 3/8"-6 spline input shaft and 2" output shaft
Gearbox Oil Capacity & Type		7 Pints of EP 80-90W oil
Deck Construction		All welded deck
Deck Material Thickness		10 Gauge (.134")
Side Skirt Material Thickness		10 Gauge (.134")
Skid Shoes		Full length weld-on skid shoes
	Standard	1/4" x 2 1/2" x 18 7/16" Long bolt-on replaceable skid shoes (Bolts to weld-on skid shoes)
	Accessory	
Stump Jumper		3/16" x 27" Oval Pan with 1" thick blade holder bar
Blades (2)		1/2" x 4" x 31" Heat treated alloy steel free-swinging high lift
Blade Bolts		Keyed with harden flat washers & locknuts.
Blade Tip Speed		17,113 FPM
Driveline		ASAE Category 4
Driveline Protection		2 Plate slip clutch
Tailwheel Mount		Welded A-arm and caster fork with 360 degree swivel
Tailwheel		4" x 8" x 15" Laminated tire with cast iron hub
Front Guard		
	Optional	Rubber Belting
	Optional	Single Chain Guard
Rear Guard		
	Standard	Metal Band
	Optional	Single Chain Guard

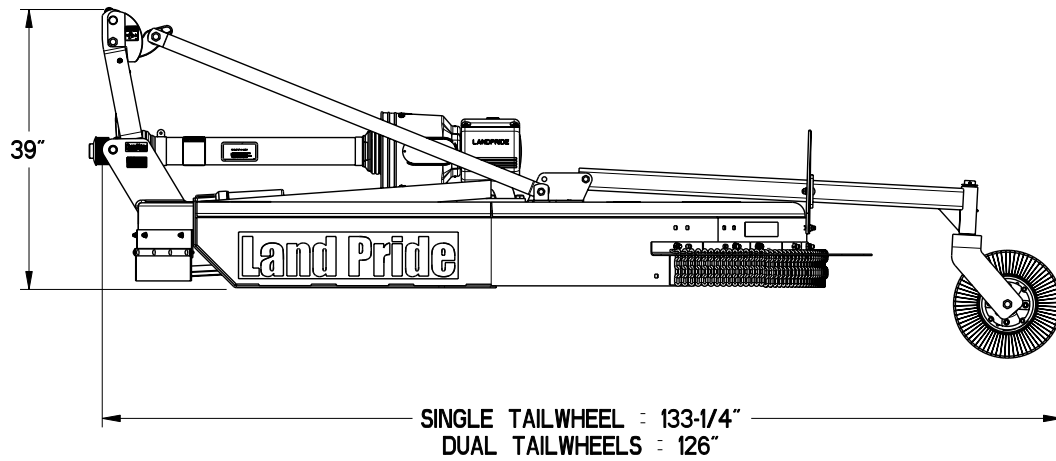
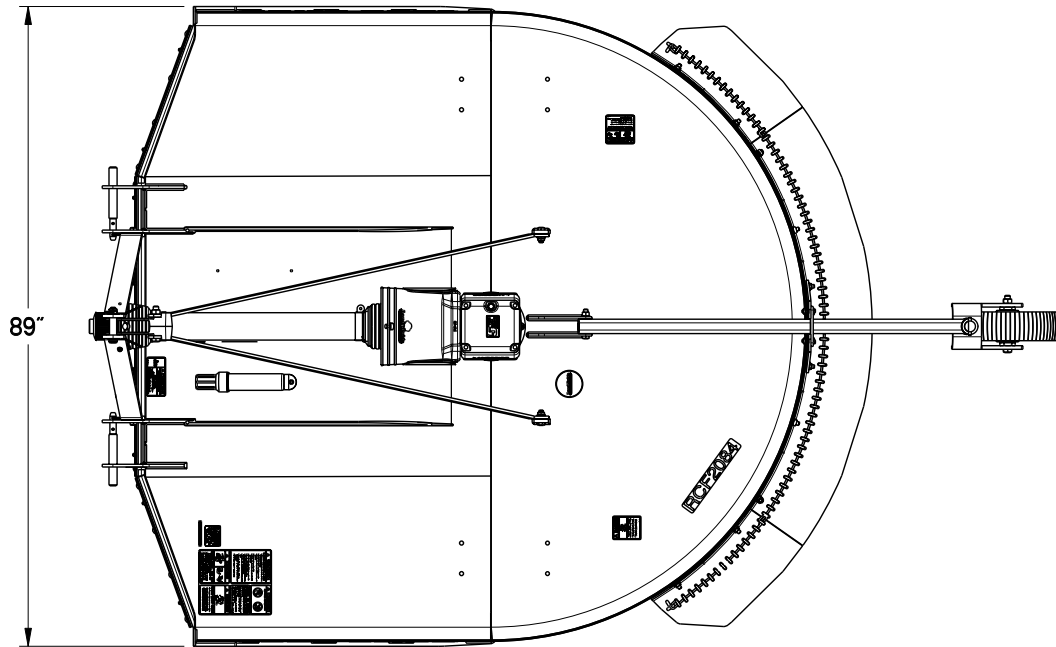

33017