

**SGC10 Series**

Specifications & Capacities			
Model No.'s	SGC1060	SGC1072	
Weight	Universal quick hitch	389 lbs	447 lbs
	Kubota B Series hitch	378 lbs	436 lbs
Width	62"	75"	
Closed height	34 1/8"	34 1/8"	
Jaw opening	39 1/2"	39 1/2"	
Number of teeth	10 Bottom & 9 Top	12 Bottom & 11 Top	
Teeth spacing	6 3/8" Bottom & 6 1/4" top		
Tooth thickness for upper and lower jaws	All outside teeth are 1/2" thick All teeth between outside teeth are 3/8" thick		
Working length of teeth	11 1/2"	11 1/2"	
Hydraulic cylinder	2" x 6" x 1 1/8" Rod		
Maximum pressure rating	3500 psi		

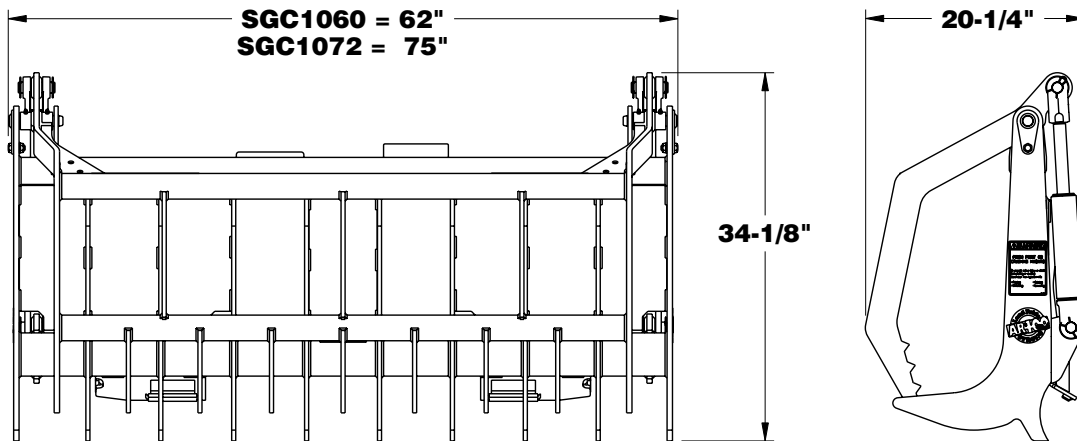

35669